

Monocentric Knee Joint

Instructions for Use

Please read this document carefully and follow the safety instructions.

Item codes: see bottom of document



Functions and benefits	4
Intended use.....	4
Residual risks, contraindications.....	4
Device specifications	5
Training.....	6
Storage/handling	6
Environmental conditions.....	6
Included in delivery	6
Bench alignment.....	7
Static Alignment	9
Dynamic alignment.....	9
Friction adjustment	9
Bumper.....	9
Locking mechanism	10
Locking spring kit	10
Maintenance	12
Cleaning and care	12
Disposal	12
Reusability	12
Compatibilities.....	13
Warnings, precautions.....	14
Compliance	14
CE Conformity.....	14
Item codes	15
IFU ID and date	15

Functions and benefits

The Rehab'Impulse Monocentric Knee Joint is a durable and versatile single-axis prosthetic knee joint with an integrated manual locking system, which can be used on either the left or right side. This monocentric knee joint provides a bending angle of up to 125°.

Intended use

This product is intended for prosthetic fitting on adults and children. This product is not intended for excessive physical activities.

Adult sizes: Approved for a body weight of up to 80 kg (P4)

Child sizes: Approved for a body weight of up to 60 kg (P3)

Residual risks, contraindications

n/a

Device specifications

Material:	PP, stainless steel
Overall length:	460mm
Pylon diameter:	25mm
Proximal connection:	M10
Locking mechanism:	Manual
Range of motion:	125°
Colours:	74-00243: Beige (adult size) 74-00244: Olive (adult size) 74-00245: Terra (adult size) 74-00240: Beige (child size) 74-00241: Olive (child size) 74-00242: Terra (child size)

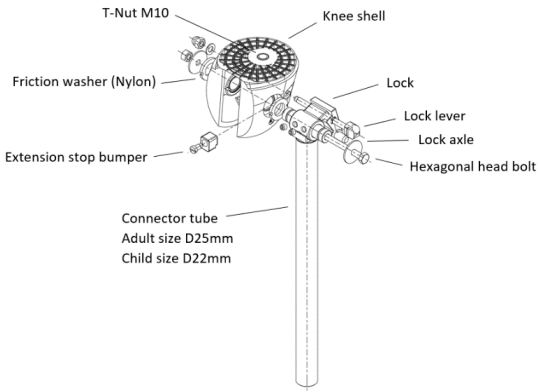

Training

Please follow the ICRC manufacturing guidelines for transfemoral prosthesis:

<https://www.icrc.org/en/doc/assets/files/other/eng-transfemoral.pdf>

Storage/handling

- Store product in dry conditions
- Store at room temperature (ideally between 15°C and 25°C)
- Keep out of direct sunlight or other sources of light with a high UV content
- Take precautionary measures against sparking and fire
- Keep in original packaging before use

Environmental conditions

Recommended environmental conditions:

- Temperature range for use : -10°C to 60°C (14°F to 140°F)
- Relative humidity 0% to 90%, no condensing situation
- Avoid exposure to dust, sand, salt water, acids and urine

Included in delivery

- 1x Monocentric Knee Joint

Bench alignment

All alignment should be done with the user's shoe fitted on the prosthetic foot. Alternatively, use a spacer under the prosthetic heel representing the effective heel height of the shoe. The monocentric knee joint is meant to be used with prosthetic components assembly kits proposed by the manufacturer (adult: 74-00134; child: 74-00223). The connection to the socket can also be achieved with a modular-type pyramid adapter (74-00337), which is compatible with other manufacturer's components (available for adult knees only).

Frontal alignment: Ensure that the pylon is in vertical position and the knee shell top surface is parallel to the ground surface. Adjust socket adduction according to user's requirements.

Lateral alignment: The socket should be mounted in flexion according to user's requirements. For a stabilised alignment, the alignment reference line should pass one centimetre frontal of the knee axis (see also the manufacturing guidelines mentioned above). This distance can be shortened depending on the user's abilities and level of amputation.

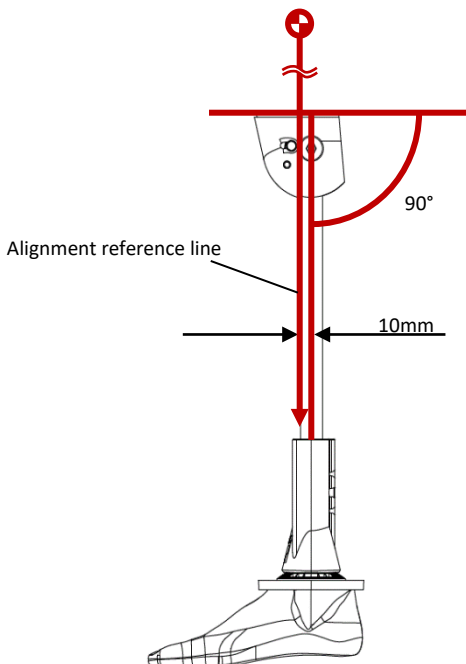

The prosthetic foot should be aligned according to the manufacturer's recommendation (as a general rule an external rotation of 5-7° is recommended). An incorrect initial position can lead to inappropriate force transfer from the ground to the prosthesis.

Static Alignment

Static alignment should be verified with the user standing in upright position, with both shoes flat on the floor and with his weight equally distributed on both legs. For more security, alignment verification is recommended to be done with the user standing between parallel bars. Tube length should be verified with the knee in full extension.

Dynamic alignment

Observe the user's gait between parallel bars. Knee angle and rotation can be adjusted by loosening the M10 bolt and sliding the convex disc and the concave cup of the Rehab'Impulse transfemoral module system. To avoid circumduction, ensure the knee axis alignment remains horizontal.

Friction adjustment

Swing friction may be adjusted using the M6 knee axis bolt and nut. Tightening the bolt and nut will increase the friction while loosening will decrease the friction and allow the knee to swing more freely. (Additional thread-locking fluid may be applied).

Bumper

Regularly check the bumper and the appropriate functioning of the locking mechanism. Replace the bumper, if worn out.

Locking mechanism

This device is equipped with a manual locking mechanism. To manipulate the locking mechanism, weight bear on the prosthetic knee in full extension and manually activate the lever. When using the knee joint for a left leg amputation, the locking lever can be disassembled and mounted with the activation knob on the lateral side of the leg.

Locking spring kit

This knee joint can be equipped with a locking spring (to be ordered separately). This locking spring activates the locking lever when the knee joint is in full extension.

To install the locking spring, follow the steps below:



Step 1:
Grind off PP boss to allow
free movement of lock
lever (grind on both sides)

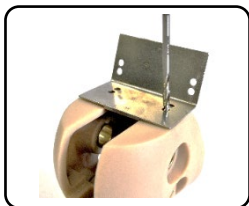

Step 2:
Drill 2x D4mm holes with
the help of the drill
template

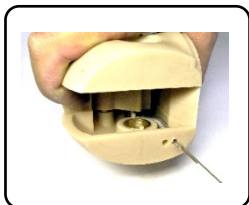

Step 3:
Attach the hook on the
long end of the spring to
the lock lever. With the
help of the mounting
hook, attach the other end
of the spring on the knee
shell



Step 4:
Verify correct functioning
of locking mechanism

Maintenance

This device is designed for low maintenance. The prosthetic component should be inspected after the first 30 days of use. After this period, it is recommended to inspect the device at least every six months for signs of unusual wear. If the device is used in a corrosive environment or subjected to excessive moisture, it is recommended to clean and lubricate the knee axis frequently.

Cleaning and care

This device can be cleaned using mild soap or solvent followed by rinsing with water. Allow device to dry completely before use. Avoid strong acid (pH=4 or less) and oxidizing agents.

This device has been engineered for a service life of three to five years depending on user's activity level. Scheduling of regular maintenance lies within the discretion of the service provider. The user shall discontinue use and report to the service provider in the event of any breakage, failure, change in function or any unusual wear.

Disposal

Users are advised to return defective or worn out products to their clinician.

Please note that disposal of this product with regular domestic waste may not be permitted in all countries of use. Not following the disposal regulations of the responsible authorities may have a detrimental impact on health and environment.

Reusability

This device is intended for single-use only.

Compatibilities

The monocentric knee joint is compatible with the Rehab'Impulse modular system. A specially designed pyramid adapter kit (74-00337) offers compatibility with standard modular tube clamp adapters.

Adult sizes:

- 74-00134 Transfemoral Alignment Kit, Adult
- 74-00337 Pyramid Adapter, For Knee Joint Adult
- 74-00789 Locking Spring Kit, For Monocentric Knee Joint, Adult/Child

Child sizes:

- 74-00223 Transfemoral Alignment Kit, Child
- 74-00227 Transfemoral Alignment Kit, Child, Connector for Adult Foot
- 74-00789 Locking Spring Kit, For Monocentric Knee Joint, Adult/Child

Spare parts

- 74-00780 Bumper Kit Adult, For Monocentric Knee Joint (pack of 10)
- 74-00781 Bumper Kit Child, For Monocentric Knee Joint (pack of 10)

Warnings, precautions

Using the product without following these instructions for use may cause injury or harm to the user and/or damage the product. This device shall be fitted by trained prosthetists only. Ensure that the approved service life of 3 million cycles is not exceeded. Do not expose the product to environmental conditions other than the one specified in this instruction. If damage is apparent or in case of doubt, do not continue using the product. Take suitable measures as required (e.g. cleaning, repair, replacement by trained P&O personal). In case of contact with salt water, acid, abrasive substances or any substance identified above, promptly clean the product in accordance with the chapter "Cleaning and Care".

Compliance

This device has been tested according to the ISO 10328 standard to 3 million load cycles.

Adult sizes: Approved for a body weight of 80kg (P4)

Child sizes: Approved for a body weight of 60kg (P3)

Depending on the user's activity level, this corresponds to a service life of three to five years. It is recommended to carry out regular safety checks.

CE Conformity

This product meets the requirements of the EU MDR 2017-745 guidelines for medical products. It has been classified as a Class I product according to the classification criteria outlined in Appendix VIII of the guidelines.

Item codes

REF	Description English
74-00243	Monocentric Knee Joint, Beige, Adult
74-00244	Monocentric Knee Joint, Olive, Adult
74-00245	Monocentric Knee Joint, Terra, Adult
74-00780	Bumper Kit Adult, For Monocentric Knee Joint (pack of 10)
74-00789	Locking Spring Kit, For Monocentric Knee Joint, Adult/Child
74-00240	Monocentric Knee Joint, Beige, Child
74-00241	Monocentric Knee Joint, Olive, Child
74-00242	Monocentric Knee Joint, Terra, Child
74-00781	Bumper Kit Child, For Monocentric Knee Joint (pack of 10)

IFU ID and date

74-02070-IFU-MonocentricKneeJoint-EN-V3.0 – 21.03.2023



Fondation Alfaset
Rue des Terreaux 48
CH-2300 La-Chaux-de-Fonds
Switzerland
+41 32 967 96 50
www.alfaset.ch
contact@alfaset.ch

